



YS10

SMALL THERMOSTAT PROTECTOR

Introduction

- High current capacity (125Vac/16A) to cut off power circuit.
- Keep small size as conventional protector MA10, and thermal sensitivity.
- Reliable long life

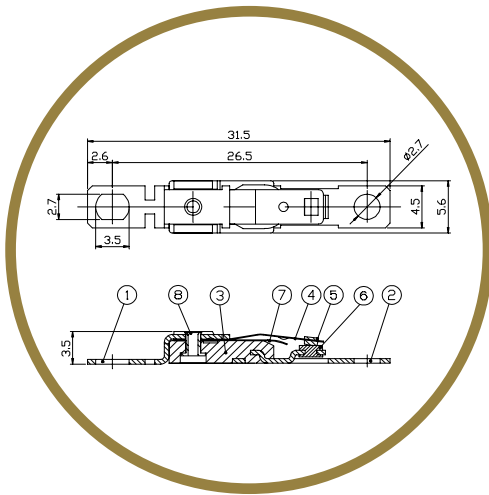

Features

YS10 was developed to protect people and property from accidents occurring on products such as Hair Dryer/Fan heater. It is an automatic resettable, incorporated thermal cut-out (Type 2C).

The YS10 pursued to enable to be used for higher wattage products, therefore highest current can be loaded through YS10, and directly cut off power line. But the distance of mounting holes is kept at same size as conventional protector MA10.



SPECIFICATIONS

Contact Capacity	12(3)A 250Vac 16(3)A 125Vac
Temperature Range	± 5K
Tolerance on Open Temperature	60 to 150°C
Max. Temp. of Switch Head	150°C
Operating Time	Continuous
Pollution Situation	Norma
Extent of Sensing Element	Whole Control

Performance

Ultimate Trip Current Curve

YS 10 Ultimate trip current vs ambient temperature

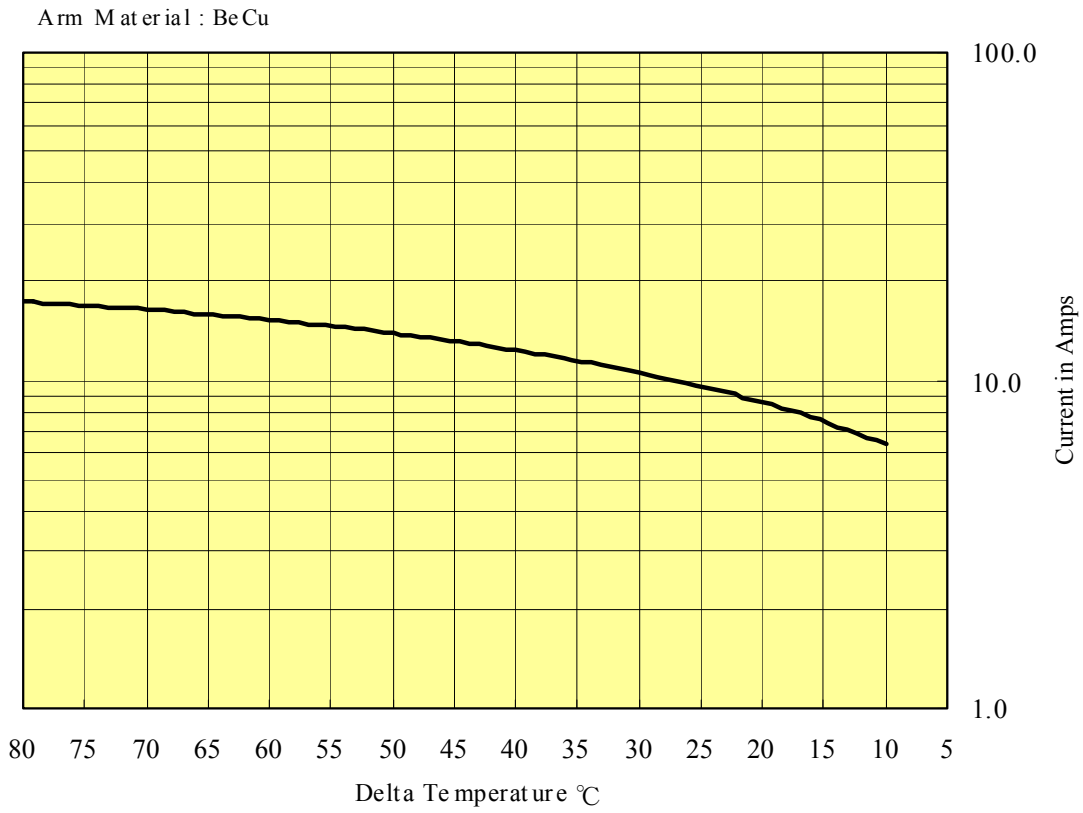



DIMENSIONS

Dimensions in mm

Width 5.6 x Length 31.5 x Height 3.5mm

Distance between each hole : 26.5mm

Hole Diameter : 2.7mm

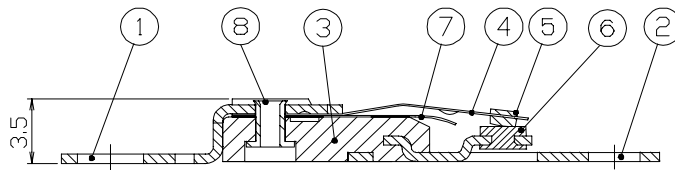
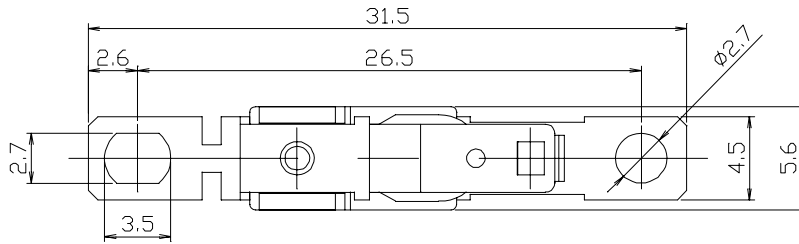

Construction

YS10 is constructed with only few parts as a simple and open design (IP00) and based on the well known thermostat technology of Texas Instruments.

1.Upper Terminal carries current to 2.Lower Terminal which is insert molded in 3.Lower Block, via 4.Movable Arm, 5.Movable Contact and 6.Stationary Contact. All parts are riveted to hold with 8.Eyelet. Refer drawing 7.Bimetal Disc is placing under 4.Movable Arm to push it up to open Contact, when 7.Bimetal Disc sensed high ambient temperature around YS10. Heat generated by 4.Movable Arm is designed properly on a combination with operation temperature and Trip current. Therefore, user could select best choice of MUST HOLD current for their product. The YS10 is mounted by various means in conjunction with (holes in) the terminals, such that adequate creepage and clearance distances are maintained between live parts and accessible metal parts.

The electrical connections are for internal wiring only and are achieved by e.g. riveting, soldering or spot welding.

Terminal Identification

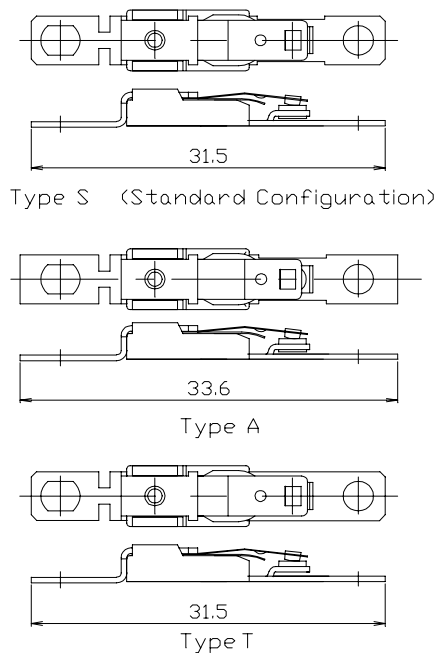



120°C operation temperature, BeCu Movable Arm, Standard Terminals and 30°C differential. (90°C reset)

YS10 - **XXY** - **T** - **(ZZ)**

YS10

Device Identification

Temperature Code Matrix and Movable Arm Identification

XX: Temperature Code Matrix

Standard Operating Temperature (°C)			
Operating Temperature	Temperature Code	Operating Temperature	Temperature Code
60°C	56	110°C	36
65°C	96	115°C	41
70°C	71	120°C	01
75°C	51	125°C	81
80°C	91	130°C	11
85°C	61	135°C	06
90°C	21	140°C	66
95°C	31	145°C	76
100°C	26	150°C	46
105°C	16		

Y: Movable Arm Identification

- A:** Titanium Copper
- B:** Beryllium Copper
- C:** Nickel Copper
- D:** Stainless Steel

Note: BeCu is only certified material for ENEC.

Termination Identification

- S:** Standard Terminals (Legnth 31.5)
- A:** Both Terminals Straight (Legnth 33.6)
- T:** PPS Insulator (Legnth 31.5)

* Standard Insulation is applied Vyloglass

Differential

Differential for Reset Temperature from Operation Temp.
Blank for Standard 30°C Differential



AGENCY APPROVALS & CERTIFICATIONS



UL	E 34618
CSA	24458
ENEC	2014531 / 17
CQC	CQC02002001338
MITI	JET99P No.0229

Sensata Technologies, Inc. ("Sensata") data sheets are solely intended to assist designers ("Buyers") who are developing systems that incorporate Sensata products (also referred to herein as "components"). Buyer understands and agrees that Buyer remains responsible for using its independent analysis, evaluation and judgment in designing Buyer's systems and products. Sensata data sheets have been created using standard laboratory conditions and engineering practices. Sensata has not conducted any testing other than that specifically described in the published documentation for a particular data sheet. Sensata may make corrections, enhancements, improvements and other changes to its data sheets or components without notice.

Buyers are authorized to use Sensata data sheets with the Sensata component(s) identified in each particular data sheet. HOWEVER, NO OTHER LICENSE, EXPRESS OR IMPLIED, BY ESTOPPEL OR OTHERWISE TO ANY OTHER SENSATA INTELLECTUAL PROPERTY RIGHT, AND NO LICENSE TO ANY THIRD PARTY TECHNOLOGY OR INTELLECTUAL PROPERTY RIGHT, IS GRANTED HEREIN. SENSATA DATA SHEETS ARE PROVIDED "AS IS". SENSATA MAKES NO WARRANTIES OR REPRESENTATIONS WITH REGARD TO THE DATA SHEETS OR USE OF THE DATA SHEETS, EXPRESS, IMPLIED OR STATUTORY, INCLUDING ACCURACY OR COMPLETENESS. SENSATA DISCLAIMS ANY WARRANTY OF TITLE AND ANY IMPLIED WARRANTIES OF MERCHANTABILITY, FITNESS FOR A PARTICULAR PURPOSE, QUIET ENJOYMENT, QUIET POSSESSION, AND NON-INFRINGEMENT OF ANY THIRD PARTY INTELLECTUAL PROPERTY RIGHTS WITH REGARD TO SENSATA DATA SHEETS OR USE THEREOF.

All products are sold subject to Sensata's terms and conditions of sale supplied at www.sensata.com SENSATA ASSUMES NO LIABILITY FOR APPLICATIONS ASSISTANCE OR THE DESIGN OF BUYERS' PRODUCTS. BUYER ACKNOWLEDGES AND AGREES THAT IT IS SOLELY RESPONSIBLE FOR COMPLIANCE WITH ALL LEGAL, REGULATORY AND SAFETY-RELATED REQUIREMENTS CONCERNING ITS PRODUCTS, AND ANY USE OF SENSATA COMPONENTS IN ITS APPLICATIONS, NOTWITHSTANDING ANY APPLICATIONS-RELATED INFORMATION OR SUPPORT THAT MAY BE PROVIDED BY SENSATA.

Mailing Address: Sensata Technologies, Inc., 529 Pleasant Street, Attleboro, MA 02703, USA.

CONTACT US

Americas

+1 508 236 2551
electrical-protection-sales@
sensata.com

Europe, Middle East & Africa

+3 174 357 8156
info-sse@list.sensata.com

Asia Pacific

EP_Asia_Public@list.sensata.
com

China +86 (21)2306 1651

India +91 (40)4033 9611

Japan +81 (45)277 7104

Korea +82 (53) 644 9685

Rest of Asia +65(6478)6860